



**YIBAI PRECISION**

**怡邦精密**

鋁合金熱處理爐，鍛造加熱爐、不氧化光輝爐、不鏽鋼固溶化爐  
、迴轉滲碳爐、滴注式氣體滲碳爐、真空氮化爐

T4 and T6 Aluminum alloy treating furnace, Continuous forging furnace, bright gardening  
annealing furnace, Stainless steel treatment furnace, Rotating gas carburizing furnace,  
Dipping type gas carburizing pit furnace, Vaccum nitriding furnace.

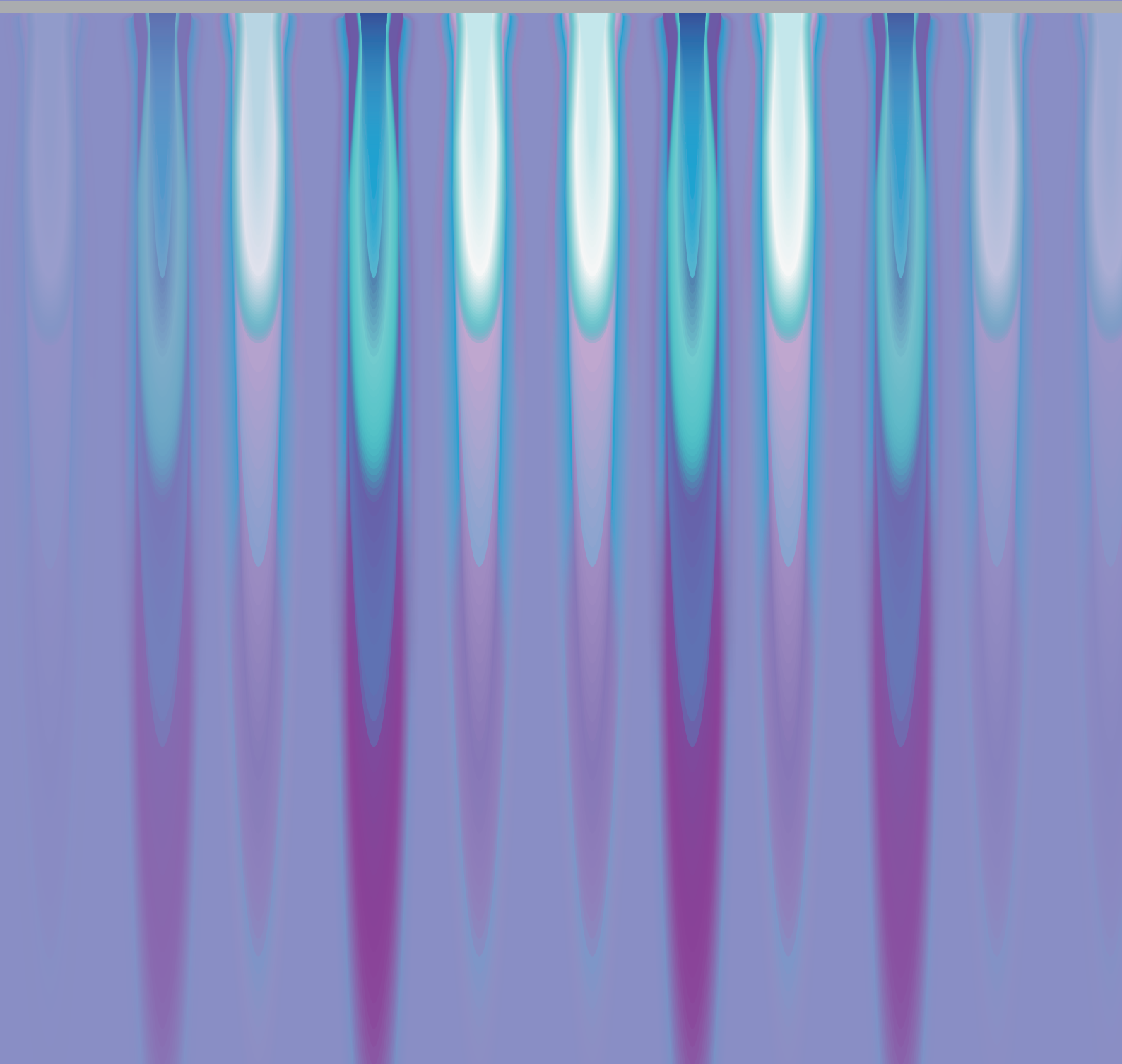

# CONTENTS



公司簡介 ABOUT US

P1



YB-11 系列 YB-11 series

P02

YB-11001

YB-13 系列 YB-13 series

P10

YB-13001  
YB-13002



YB-11 系列 YB-11 series

P04

YB-11002  
YB-11003

YB-13 系列 YB-13 series

P12

YB-13003  
YB-13004



YB-11 系列 YB-11 series

P05

YB-11004

YB-13 系列 YB-13 series

P13

YB-13005  
YB-13006  
YB-13007A  
YB-13007B  
YB-13007C



YB-12 系列 YB-12 series

P06

YB-12001  
YB-12002  
YB-12003A  
YB-12003B

YB-13 系列 YB-13 series

P13

YB-13008E  
YB-13008G



## 公司簡介

怡邦精密為專業熱處理設備製造商，彙集富有各領域經驗豐富的專業人員所組成的精英團隊，力求提供穩定且可信賴的熱處理設備給客戶，為客戶提升熱處理產品品質及降低生產成本，建立客戶對怡邦的滿意度和信賴感。

怡邦主要產品有鋁合金 T4 固溶化爐、鋁合金 T6 時效處理爐，鍛造加熱爐、不氧化光輝爐、不鏽鋼固溶化處理爐、迴轉滲碳爐、滲碳爐、真空氮化爐、球化退火爐和一般加熱爐等各種熱處理設備。設備廣泛應用於航空航太、軍事工業、汽車零部件、工程機械、手工具、商業熱處理等各種行業的熱處理加工。產品銷售地區遍及中國、臺灣、印尼、越南、馬來西亞等地，獲得各地客戶青睞。



## ABOUT US

Yibai precision Co., Ltd. is composed by a group of experienced experts. We behave as a creative and high-quality furnaces producer. Our target is all of our furnaces that are relied and qualified by our customer. Our main products are T4 and T6 Aluminum alloy treating furnace, continuous forging furnace, bright gardening annealing furnace, stainless Steel treatment furnace, rotating gas carburizing furnace, dipping type gas carburizing pit furnace, Vaccum nifriding furnace, spherical annealing furnace... etc. and widely used in the field of aerospace, military, motor parts, hand tool industry and other industry. Our furnaces have been installed on China, Taiwan, Vietnam, Malaysia, Indonesia. Yibia precision Co., Ltd. always offer the best and professional service for you.





## YB-11001

吊鐘式 T4 鋁合金熱處理爐 方型 (A)/ 圓型 (B)

**YB-11001 Hanger Bell Type Electrical Heating Al-Alloy T4 Treating Furnace Rectangular (A) / Round (B) Type**

方型 (A) 規格 / SPECIFICATIONS				
型號 Model	內體尺寸 Crucible size	工作空間 Working space	動力 Power	最高溫度 Max. temp
YB-11001A-090909	L1050 x W1050 x H1600mm	L900 x W900 x H900mm	120Kw	650°C
YB-11001A-121212	L1350 x W1350 x H1900mm	L1200 x W1200 x H1200mm	150Kw	650°C
YB-11001A-151515	L1650 x W1650 x H2200mm	L1500 x W1500 x H1500mm	170Kw	650°C
應用範圍 / Application				
鋁合金 T4 固溶處理，入水時間：10 秒內。 / T4 solution melting treatment for Al-alloy, Dropping time: within 10 sec.				

※ 可按客戶規格設計製造 Tailor made at customer's request.

## 圓型 (B) 規格 / SPECIFICATIONS

型號 Model	內體尺寸 Crucible size	工作空間 Working space	動力 Power	最高溫度 Max. temp
YB-11001B-0912	Φ1050 x H1900mm	Φ900 x H1200mm	110Kw	650°C
YB-11001B-1015	Φ1200x H2200mm	Φ1050 x H1500mm	130Kw	650°C
YB-11001B-1218	Φ1350 x H2500mm	Φ1200x H1800mm	160Kw	650°C

應用範圍 / Application

鋁合金 T4 固溶處理，入水時間：10 秒內。  
T4 solution melting treatment for Al-alloy, Dropping time: within 10 sec.

※ 可按客戶規格設計製造 Tailor made at customer's request.

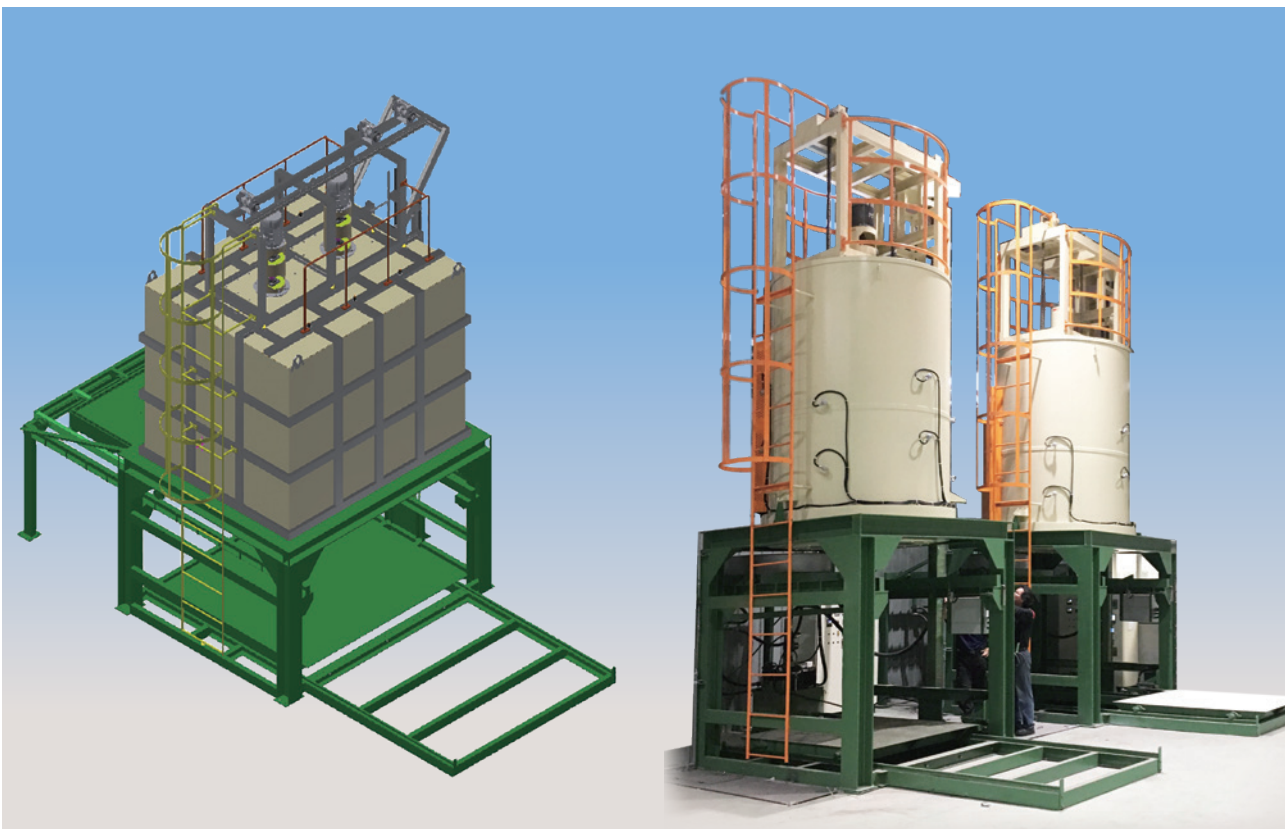

## 設備規格

- 爐體結構採用 SS400 結構用鋼製作，爐內保溫層採用耐火磚、斷熱磚及其他保溫材等進行築爐。
- 加熱線使用瑞典製電熱線，加工成波浪狀固定於爐壁內緣。
- 裝載熱風循環裝置使爐內溫度快速均溫，熱循環風車座有冷卻水循環保護防止軸承過熱失油咬死。
- 單區獨立控制溫度，上層及下層電力輸出並配合溫控表 PID 自動演算。
- 溫度偵測方式，主要為 6 點偵測點，其中 1 點作為主偵測點；實際偵測點數可依客戶需求增減。
- 電控系統可搭配紀錄器和人機介面作整合，並有超溫、爐門、台車保護等控制系統。
- 淬火方式採用水淬冷卻方式；淬火落水時間為 10 秒內。
- 客製化設備，皆可以按客戶所需規格設計。

# YB-11002

箱型台車式 T6 鋁合金時效爐

**YB-11002 Car Bottom Type Electrical Heating**

**Al-Alloy T6 Aging Treating Furnace**

規格 / SPECIFICATIONS				
型號 Model	爐室尺寸 Interior space	工作空間 Working space	動力 Power	最高溫度 Max. temp
YB-11002-090912	L1400 x W1050 x H1400mm	L900 x W900 x H1200mm	45Kw	350°C
YB-11002-101015	L1550 x W1200 x H1700mm	L1050 x W1050 x H1500mm	65Kw	350°C
YB-11002-121218	L1700 x W1350 x H2000mm	L1200 x W1200 x H1800mm	85Kw	350°C
應用範圍 / Application				
鋁合金 T6 時效處理。 / T6 aging treatment for AL-alloy.				



# YB-11004

## 電氣式連續熱風鍛造爐

### YB-11004 Electrical Heating Hot Air Circulation Continuous Forging Furnace

#### 規格 / SPECIFICATIONS

型號 Model	爐室尺寸 Interior space	網面 Belt size	入口長度 Inlet Length	出口長度 Outlet Length	動力 Power	最高溫度 Max. temp
YB-11004-4040	L4000 x W420 x H160mm	400mm	1000mm	250mm	90Kw	650°C
YB-11004-6040	L6000 x W420 x H160mm	400mm	1000mm	250mm	120Kw	650°C
YB-11004-8040	L8000 x W420 x H160mm	400mm	1200mm	250mm	150Kw	650°C
YB-11004-10040	L10000 x W420 x H160mm	400mm	1200mm	250mm	180Kw	650°C
YB-11004-12060	L12000 x W620 x H250mm	600mm	1200mm	250mm	290Kw	650°C

#### 應用範圍 / Application

鍛造用加熱爐，適用於鋁合金鍛造前加熱。

The high temp heating for Al-alloy hand-tool hot forging, warm & hot forging etc.



# YB-12001

網帶式不氧化光輝爐

## YB-12001 Net Belt Type Non-Oxidized Bright Hardening Annealing Furnace

規格 / SPECIFICATIONS						
型號 Model	隧道口徑 Tunnel inlet (W*H)	網面 Belt size	加熱長度 Heating length	冷卻長度 Cooling length	動力 Power	最高溫度 Max. temp
YB-12001-3015	170x70 mm	150mm	3000mm	4000mm	90Kw	1150°C
YB-12001-4020	220x70/90mm	200mm	4000mm	5000mm	120Kw	1150°C
YB-12001-5030	320x90 mm	300mm	5000mm	6000mm	160Kw	1150°C

應用範圍 / Application

不鏽鋼產品之管、線、帶製品之退火、燒結熱處理，和各種精密零件焊接，達到不氧化亦不變形的效果。  
 For SUS steel products such as wire ,Strip ,punch pressings, forgings, castings etc. copper alloys, powder metallurgy products, table-ware, watch cases etc. annealing, sintering etc. the non-deformation and non-oxidation treatment of precision welded parts.

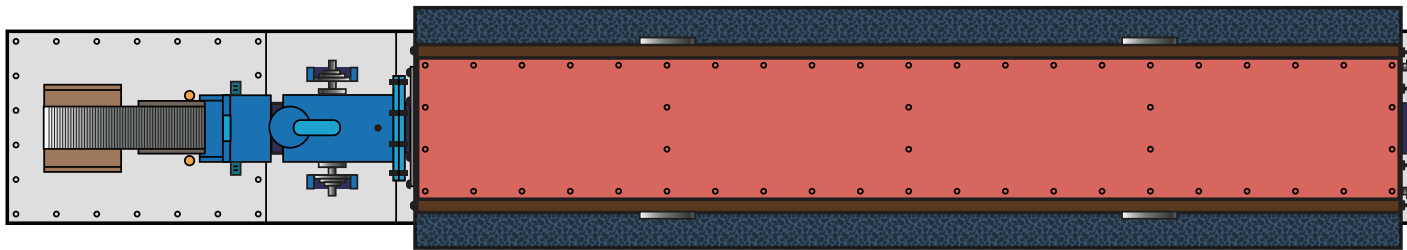



# YB-12002

## 氨氣分解氣氛爐

### YB-12002 Ammonia Gas Decomposing Furnace

規格 / SPECIFICATIONS		
型號 Model	動力 Power	最大氣體產生量 Max. temp
YB-12002-15	16Kw	15m <sup>3</sup>
YB-12002-25	30Kw	25m <sup>3</sup>
YB-12002-30	45Kw	30m <sup>3</sup>
應用範圍 / Application		
氨氣分解保護。 / The decomposition of ammonia gas for an active-atmosphere.		

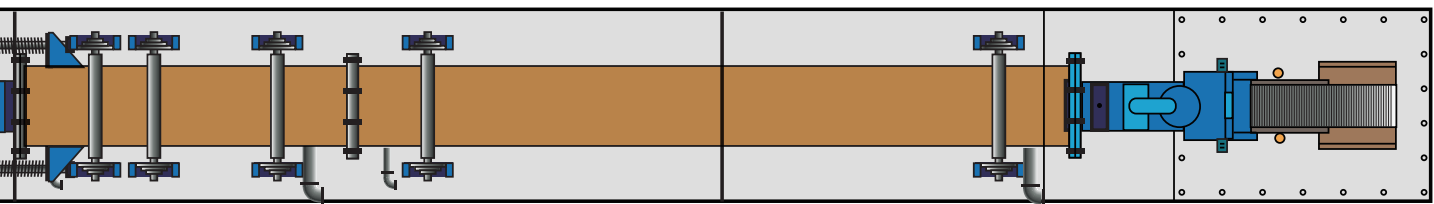

# YB-12003A

箱型台車式不銹鋼固熔化處理爐

## YB-12003A Car Bottom Type Stainless Steel Treatment Furnace

規格 / SPECIFICATIONS				
型號 Model	爐室尺寸 Interior space	工作空間 Working space	動力 Power	最高溫度 Max. temp
YB-12003A-060605	L1200 x W950 x H950mm	L600 x W600 x H500mm	100Kw	1100 °C
YB-12003A-090908	L1500 x W1250 x H1250mm	L900 x W900 x H800mm	120Kw	1100 °C
YB-12003A-111010	L1700 x W1350 x H1350mm	L1100 x W1000 x H1000mm	160Kw	1100 °C
應用範圍 / Application				
不鏽鋼鑄零件之析出硬化，消磁及固溶處理。 / Hardening, solution and demagnetizing treatment of stainless steel.				

※ 可按客戶規格設計製造 Tailor made at customer's request.



# YB-12003B

網帶式不鏽鋼處理爐

## YB-12003B Net Belt Type Stainless Steel Treatment Furnace

規格 / SPECIFICATIONS				
型號 Model	爐室尺寸 Interior space	網面 Belt size	動力 Power	最高溫度 Max. temp
YB-12003B-4040	L4000 x W420 x H200mm	400mm	105Kw	1100°C
YB-12003B-6040	L6000 x W420 x H200mm	400mm	140Kw	1100°C
適用範圍 / Application				
不鏽鋼鑄零件之析出硬化，消磁及固溶處理。 / Hardening, solution and demagnetizing treatment of stainless steel.				

※ 可按客戶規格設計製造 Tailor made at customer's request.

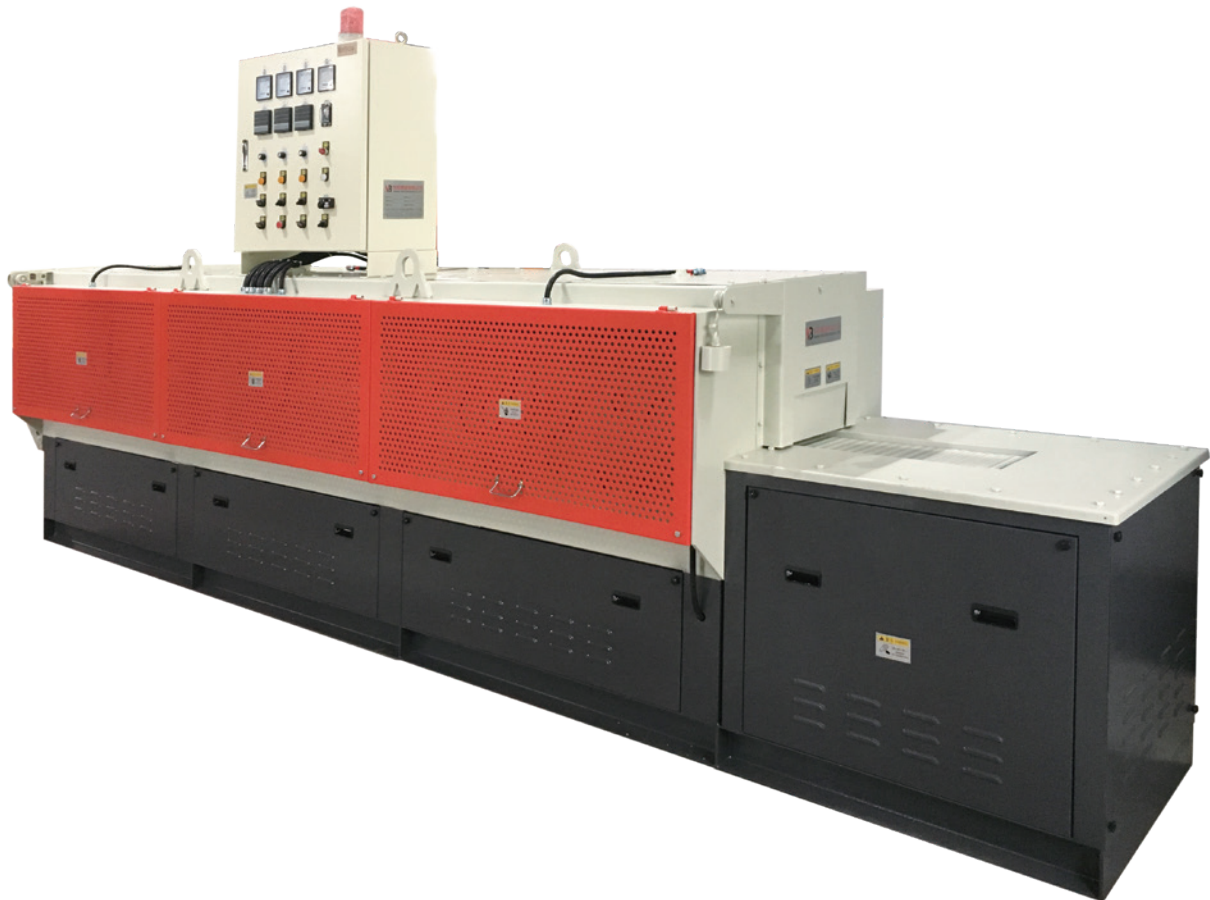

# YB-13001

圓型 - 電氣式迴轉氣體滲碳爐

## YB-13001 Round Type Electrical Heating Rotating Gas Carburizing Furnace

規格 / SPECIFICATIONS			
型號 Model	內體尺寸 Crucible size	動力 Power	最高溫度 Max. temp
YB-13001-0406	Φ400xL600 mm	60Kw	1000°C
YB-13001-0507	Φ500xL700 mm	80Kw	1000°C
YB-13001-0608	Φ600xL800 mm	100Kw	1000°C
適用範圍 / Application			
高、中、低碳鋼小零件，淬火，滲碳，燒鈍。 Quenching, carburizing small parts of carbon alloyed steels.			

※ 可按客戶規格設計製造 Tailor made at customer's request.



## YB-13002

### 滴注式氣體滲碳爐整套設備

### YB-13002 Whole Set Equipment Of Dipping Type Gas Carburizing Pit Furnace

#### YB-13002A 滲碳爐 / Carburizing Furnace

規格 / SPECIFICATIONS				
型號 Model	內體尺寸 Crucible size	工作空間 Working space	動力 Power	最高溫度 Max. temp
YB-13002A-0509	Φ650xH1500 mm	Φ500xH900 mm	85Kw	1000°C
YB-13002A-0612	Φ750xH1800 mm	Φ600xH1200 mm	100Kw	1000°C
YB-13002A-0714	Φ850xH2000 mm	Φ700xH1400 mm	120Kw	1000°C
適用範圍 / Application				
高、中、低碳鋼之滲碳、調質和退火等。 / Carburizing and annealing of carbon steels.				

※ 可按客戶規格設計製造 Tailor made at customer's request.

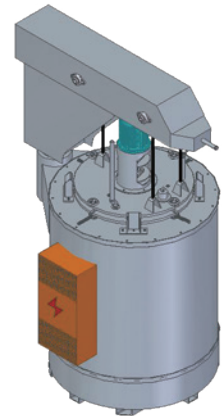

#### YB-13002B 淬火油槽 / Quench Oil Tank

規格 / SPECIFICATIONS				
型號 Model	內體尺寸 Crucible size	工作空間 Working space	動力 Power	槽室容量 Oil tank volume
YB-13002B-1017	Φ2200xH2800xL3200 mm	Φ1000xH1700 mm	10Kw	10000 L
YB-13002B-1520	Φ2700xH3050xL3600 mm	Φ1500xH2000 mm	15Kw	15000 L
應用範圍 / Application				
淬火冷卻。 / Quench cooling.				

※ 可按客戶規格設計製造 Tailor made at customer's request.

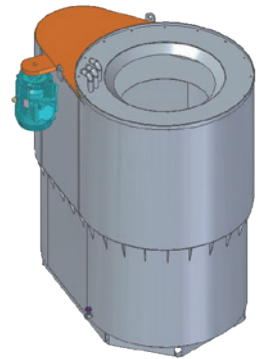

#### YB-13002C 坩鍋流氣式熱風爐 / Crucible Hot Air Circulating Furnace

規格 / SPECIFICATIONS				
型號 Model	內體尺寸 Crucible size	工作空間 Working space	動力 Power	最高溫度 Max. temp
YB-13002C-0509	Φ650xH1300 mm	Φ500xH900 mm	70Kw	700°C
YB-13002C-0612	Φ750xH1600 mm	Φ600xH1200 mm	85Kw	700°C
YB-13002C-0715	Φ850xH1800 mm	Φ700xH1500 mm	100Kw	700°C
應用範圍 / Application				
高、中、低碳鋼之回火處理。 / Tempering of carbon steels.				

※ 可按客戶規格設計製造 Tailor made at customer's request.

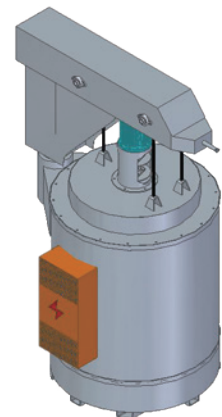

## YB-13003 箱型電氣式台車加熱爐

### YB-13003 Electrical Car Mobile Type Annealing Furnace

規格 / SPECIFICATIONS				
型號 Model	內體尺寸 Crucible size	工作空間 Working space	動力 Power	最高溫度 Max. temp
YB-13003-100606	L1500 x W800 x H800mm	L1000 x W600 x H600mm	70Kw	900°C
YB-13003-201010	L2500 x W1200 x H1200mm	L2000 x W1000 x H1000mm	120Kw	900°C
YB-13003-301212	L3500 x W1400 x H1400mm	L3000 x W1200 x H1200mm	180Kw	900°C
應用範圍 / Application				
金屬零件、軸心等之加熱回火及調質退火處理。 / The heating, annealing & tempering treatment for metallic parts or mandrel. 瓦斯、柴油加熱均可。 / Gas or diesel heating.				

※ 可按客戶規格設計製造 Tailor made at customer's request.

#### 設備規格

- 爐體結構採用 SS400 結構用鋼製作，爐內保溫層採用耐火磚及保溫磚等進行築爐保溫。
- 加熱線使用瑞典製電熱線，加工成波浪狀並固定於爐壁左右側。
- 可單區（分區）獨立控制溫度，溫控表 PID 自動演算控制加熱電流輸出大小。
- 風葉結構採用不鏽鋼風葉，可使爐室內溫度流動性佳。
- 客製化設備，皆可以按客戶所需規格設計。



## YB-13004 箱型電氣式加熱爐

### YB-13004 Electrical Type Hot Air Circulating Furnace

規格 / SPECIFICATIONS				
型號 Model	內體尺寸 Crucible size	工作空間 Working space	動力 Power	最高溫度 Max. temp
YB-13004-040404	L600 x W500 x H500mm	L400 x W400 x H400mm	40Kw	900°C
YB-13004-060606	L700 x W700 x H700mm	L600 x W600 x H600mm	60Kw	900°C
YB-13004-080808	L800 x W900 x H900mm	L800 x W800 x H800mm	80Kw	900°C
應用範圍 / Application				
金屬零件加熱回火及調質退火處理。 / The heating, annealing & tempering treatment for metallic parts.				

※ 可按客戶規格設計製造 Tailor made at customer's request.

# YB-13005 圓型真空式氮化爐

## YB-13005 Round Type Vacuum Nitriding Furnace

規格 / SPECIFICATIONS				
型號 Model	內體尺寸 Crucible size	工作空間 Working space	動力 Power	最高溫度 Max. temp
YB-13005-0408	ø600 x H1400mm	ø400 x H800mm	60Kw	600°C
YB-13005-0610	ø800 x H1600mm	ø600 x H1000mm	80Kw	600°C
YB-13005-0812	ø1000 x H1800mm	ø800 x H1200mm	100Kw	600°C
應用範圍 / Application				
金屬零件、模具等氣體氮化熱處理。 / Nitriding treatment of steel and mold products.				

※ 可按客戶規格設計製造 Tailor made at customer's request.

### 設備規格

- 爐體結構採用 SS400 結構用鋼製造，爐內保溫層採用耐火磚及斷熱磚等保溫材料築爐完成。
- 內體結構採用 SUS304 不銹鋼板焊接成型，完工後送至修整平行度。
- 加熱線採用瑞典進口電熱線，加工成波浪狀固定於爐壁下方內緣。
- 裝載熱風循環裝置使爐內溫度快速均溫，熱循環風車座有冷卻水循環保護防止軸承過熱失油咬死。
- 電控系統可搭配紀錄器和人機介面作整合，並配有真空、入藥、超溫保護等控制系統。
- 溫度偵測點依客戶需求增減，一般為 2 點溫度偵測點。
- 客製化設備，皆可以按客戶所需規格設計。



# YB-13006 圓型坩鍋球化退火爐

## YB-13006 Round Crucible Spherical Annealing Furnace

規格 / SPECIFICATIONS				
型號 Model	內體尺寸 Crucible size	工作空間 Working space	動力 Power	最高溫度 Max. temp
YB-13006-0814	Φ1000xH2000 mm	Φ800xH1400 mm	130Kw	950°C
YB-13006-1218	Φ1400xH2400 mm	Φ1200xH1800 mm	180Kw	950°C
YB-13006-1620	Φ1800xH2600 mm	Φ1600xH2000 mm	230Kw	950°C
YB-13006-2022	Φ2000xH2800 mm	Φ2000xH2200 mm	280Kw	950°C

**應用範圍 / Application**

汽、機車零件、手工具等鍛品，冷鍛退火處理。  
Cold forging parts annealing treatment for motor-mobile parts, hand tool and forging products.

※ 可按客戶規格設計製造 Tailor made at customer's request.

### 設備規格

爐體結構：1. 爐體採用 SS400 結構用鋼製造，爐內保溫層採用耐火磚及保溫磚等保溫材料築爐完成。

2. 爐體上部採用陶瓷纖維棉等耐溫材料製成軟性密封墊圈，可隔阻熱能外溢。
3. 爐蓋採用手動方式旋轉開啟。
4. 加熱線均採用瑞典製電熱線。

內體結構：1. 內體採用不鏽鋼板油壓、滾圓成型再焊接，製成後進行探傷測試。

2. 爐蓋也採用不鏽鋼板並填滿保溫材料等製成，製成後進行探傷測試。
3. 裝載熱風循環裝置，風葉由 SUS310 不鏽鋼製成，使爐內可以快速達到均溫。

電控箱系統可搭配紀錄器和人機介面作整合，並分區溫度控制，每區均可配合溫控表 PID 自動演算。

溫度偵測方式，每區各有 1 點偵測點給予溫度控制。

客製化設備，皆可以按客戶所需規格設計。





## YB-13007A 電氣式坩堝鹽浴爐

### YB-13007A Electric crucible salt-bath furnaces

規格 / SPECIFICATIONS			
型號 Model	爐室尺寸 Furnace body size	動力 Power	最高溫度 Max. temp
YB-13007A-0305	ø300xH500 mm	40Kw	1050 °C
YB-13007A-0506	ø400xH600 mm	55Kw	1050 °C
YB-13007A-0810	ø600xH950 mm	80Kw	1050 °C
應用範圍 / Application			
高中碳鋼、模具金屬零件之滲碳處理。 / 液體回火處理。 Treatment for high, medium carbon steel, molding & metal parts etc. / Liquid tempering treatment.			

※ 可按客戶規格設計製造 Tailor made at customer's request.

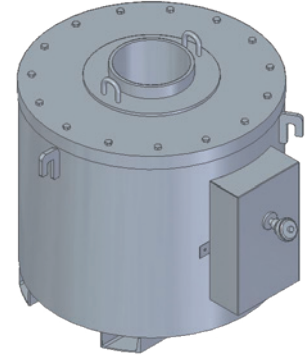

## YB-13007B 高溫電極鹽浴爐

### YB-13007B Hi-temperature electrical salt-bath furnace

規格 / SPECIFICATIONS			
型號 Model	爐室尺寸 Furnace body size	動力 Power	最高溫度 Max. temp
YB-13007B-0305	ø300xH450 mm	60KVA	1200 °C
YB-13007B-0506	ø400xH550 mm	80KVA	1200 °C
YB-13007B-0810	ø600xH900 mm	120KVA	1200 °C
應用範圍 / Application			
高中碳鋼、模具金屬零件之滲碳處理。 / 液體回火處理。 Treatment for high, medium carbon steel, molding & metal parts etc. / Liquid tempering treatment.			

※ 可按客戶規格設計製造 Tailor made at customer's request.

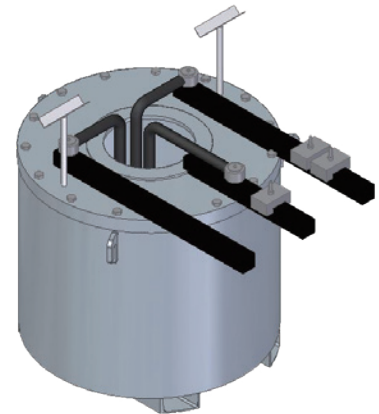

## YB-13007C 電氣式液體恆溫回火爐

### YB-13007C Constant temperature tempering bath

規格 / SPECIFICATIONS			
型號 Model	爐室尺寸 Furnace body size	動力 Power	最高溫度 Max. temp
YB-13007C-040303	L400 x W400 x H500mm	45Kw	600 °C
YB-13007C-060606	L500 x W500 x H600mm	60Kw	600 °C
YB-13007C-100808	L600 x W600 x H950mm	70Kw	600 °C
應用範圍 / Application			
高中碳鋼、模具金屬零件之滲碳處理。 / 液體回火處理。 Treatment for high, medium carbon steel, molding & metal parts etc. / Liquid tempering treatment.			

※ 可按客戶規格設計製造 Tailor made at customer's request.

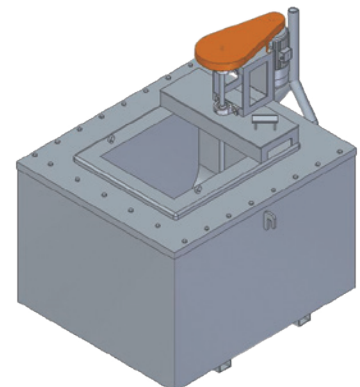

# YB-13008E

電氣加熱 - 鐘罩式光輝燒鈍爐

YB-13008E Electrical Heating Bell Type Bright Annealing Furnace

規格 / SPECIFICATIONS				
型號 Model	內體尺寸 Crucible size	工作空間 Working space	動力 Power	最高溫度 Max. temp
YB-13008E-1018	Φ1200xH2800 mm	Φ1000xH1800 mm	200Kw	950°C
YB-13008E-1620	Φ1800xH3000 mm	Φ1600xH2000 mm	300Kw	950°C
YB-13008E-2420	Φ2600xH3000 mm	Φ2400xH2000 mm	350Kw	950°C

應用範圍 / Application

大型金屬物件之光輝退火和調質處理。  
Bright annealing, tempering etc., for large steel product.

※ 可按客戶規格設計製造 Tailor made at customer's request.



# YB-13008G

瓦斯加熱 - 鐘罩式光輝燒鈍爐

YB-13008G Gas Heating Bell Type Bright Annealing Furnace

## 規格 / SPECIFICATIONS

型號 Model	內體尺寸 Crucible size	工作空間 Working space	動力 Power	最高溫度 Max. temp
YB-13008G-1018	Φ1200xH2800 mm	Φ1000xH1800 mm	400000kcal/hr	950°C
YB-13008G-1620	Φ1800xH3000 mm	Φ1600xH2000 mm	600000kcal/hr	950°C
YB-13008G-2420	Φ2600xH3000 mm	Φ2400xH2000 mm	700000kcal/hr	950°C

應用範圍 / Application

大型金屬物件之光輝退火和調質處理。  
Bright annealing, tempering etc., for large steel product.

※ 可按客戶規格設計製造 Tailor made at customer's request.



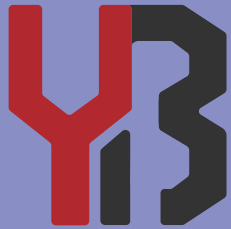

**YIBAI PRECISION**

**怡邦精密有限公司 TAIWAN YIBAI PRECISION CO., LTD.**

Tel: +886-4-23359247 ■ Fax: +886-4-23350121 ■ Email: [YIBAI@ybfurnaces.com.tw](mailto:YIBAI@ybfurnaces.com.tw)

台灣 台中市41468烏日區太明路成豐巷215弄58號  
No.58, Aly. 215, Chengfeng Ln., Taiming Rd., Wuri Dist., Taichung City 414, Taiwan



[www.ybfurnaces.com.tw](http://www.ybfurnaces.com.tw)